

## Pompe SACEMI - Type MP



**Pompe machine-outil pour transfert de fluides contenant des impuretés**

Moteur triphasé 220/380V - Classe F - IP55

Température de liquide max. : 90°C

**Applications :**

- Machines outils (perçuses, tours, fraiseuses)
- Machines de traitement du verre
- Systèmes de filtration

### > Caractéristiques et dimensions

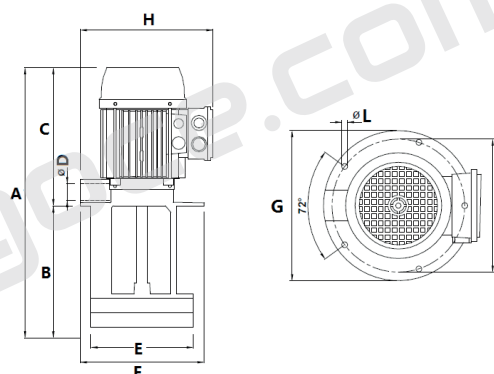
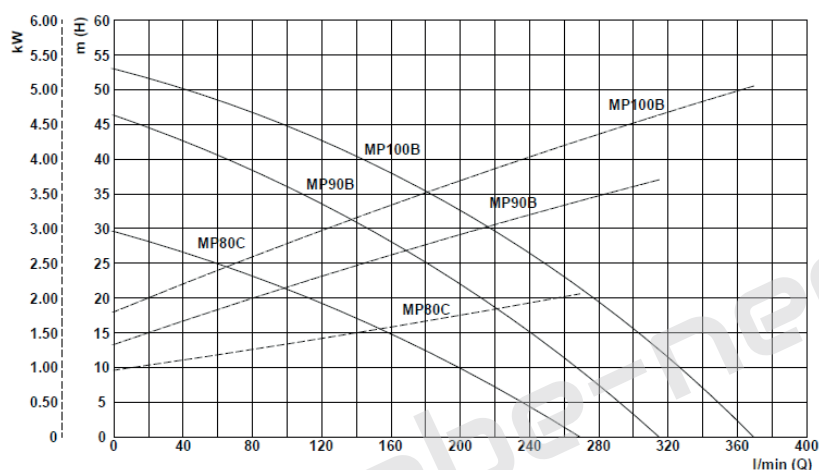

Réf. ABE	kW		A mm	B mm	C mm	D	E mm	F mm	G mm	H mm	I mm	L mm	
	Abs.	Nom.											
POMP.MP80C230			517	230									
POMP.MP80C280	1,86	1,50	567	280									
POMP.MP80C355			642	355	287	1"	190	-	230	245	204	9	
POMP.MP80C470			757	470									
POMP.MP90B265	3,58	3,00	590	265									
POMP.MP90B315			640	315									
POMP.MP90B390			715	390	325	1"	190	-	230	255	204	9	
POMP.MP90B505			830	505									
POMP.MP100B265	4,85	4,00	625	265									
POMP.MP100B315			675	315									
POMP.MP100B365			725	365	360	1 1/4"	202	220	250	275	235	9	
POMP.MP100B415			775	415									
POMP.MP100B595			955	595									